

Fax 'n' Go Quick Guide

Getting Started

Connect all components as shown below.

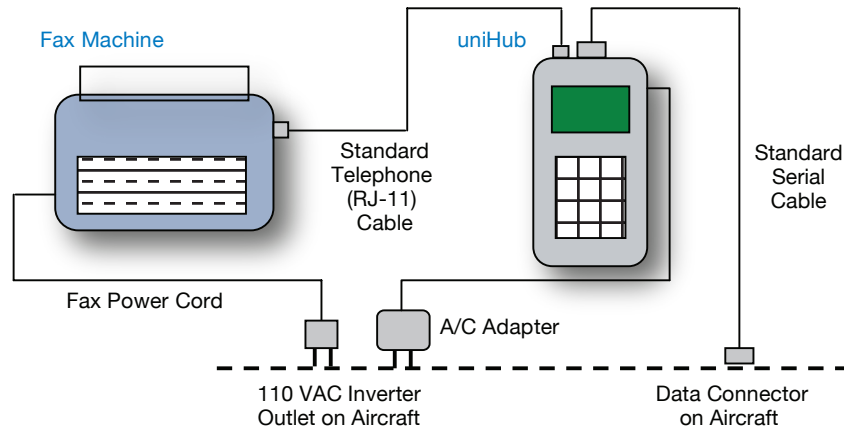

Sending a Fax

To send a fax:

1. Turn on fax machine and uniHub. The uniHub initialization process is complete when the second LED from the left (#2) stays on continuously.
2. Verify that your Iridium phone is on and registered. (Verify that the **No Svc** indicator is off.)
3. Insert the document to be sent into the fax machine.
4. Dial the destination fax number on the fax machine. Dial using the format: Country Code + Phone Number. Do not dial 00 first.

Example (USA): Dial 1.303.926.8970

5. Press **Send** on the fax machine.

Fax 'n' Go Quick Guide

Receiving a Fax

To receive a fax:

1. Have sender transmit the fax to the mailbox number that was assigned when your fax service was set up. (The fax is sent to On-Go's server prior to transmission to the aircraft.)
2. Have sender make a voice call to the aircraft, notifying recipients of an incoming fax.
3. Aboard the aircraft, ensure that the fax machine and uniHub are connected as shown in *Getting Started*.
4. Turn on all the fax equipment as described in Step 1 of *Sending a Fax*.
5. The uniHub will connect over your Iridium phone to On-Go's ground-based server, and upload the waiting fax.
6. When the upload is complete, the uniHub will transmit the fax to the fax machine on the aircraft.

*Need help? Call us.
AirCell Customer Service:
AIR1 (2471)
001.303.379.0278*

